



CLEAN IN PLACE MODEL CIP2



**Manufactured With Pride
In The USA**

www.amerewater.com • 800-535-5585

AmeriWater • 3345 Stop 8 Rd. • Dayton, OH 45414

Part Number: 98-0008
Revision: G

TABLE OF CONTENTS

1. OBJECTIVE	1
2. CHEMICALS REQUIRED	1
3. SET UP	2
4. INSTALLATION DIAGRAM	4
5. HIGH pH CLEANING	6
6. LOW pH CLEANING	8
7. AMERI WATER IRO SPECIFIC INSTRUCTIONS	10
8. SPARE PARTS LIST	10

1. OBJECTIVE

The objective of the Clean In Place (CIP) system is to introduce high pH and low pH membrane cleaners to the AmeriWater MRO system at low pressure and high velocity. This action removes scale and organic contaminants from the MRO membranes and improves system performance.

2. CHEMICALS REQUIRED

AmeriClean A (P/N 37-0004) low pH cleaner for removing inorganic scale and metals from polyamide thin-film composite (3 lb (800 ml) of AmeriClean A powder is required per membrane cleaning). AmeriClean A effectively removes the following foulants:

- Calcium Carbonate
- Calcium Sulfate
- Barium Sulfate
- Strontium Sulfate
- Iron
- Metal Oxides

AmeriClean B (P/N 37-0005) high pH cleaner for removing acid insoluble foulants from polyamide thin-film composite (3 lb (1,110 ml) of AmeriClean B powder is required per membrane cleaning). AmeriClean B effectively removes the following foulants:

- Silt
- Colloids
- Organics
- Microbiological
- Acid Insolubles
- Mucilaginous Material

WARNING: Wear appropriate eye and skin protection when handling the membrane cleaning chemicals. The cleaners are high pH and low pH chemicals that may cause severe chemical burns. Read the MSDS for further information.

WARNING: Never allow AmeriClean A and AmeriClean B to mix! Mixing the chemicals will cause an exothermic reaction which may result in serious injury and/or damage to the equipment! Flush the system thoroughly and verify that the pH of the reject water is neutral prior to introducing another chemical!

WARNING: AmeriClean A and B membrane cleaners are for polyamide thin-film membranes only and cannot be used on cellulose acetate membranes.

3. SET UP



1. Remove the hoses and pump from the CIP tank (pump, hoses and fittings are shipped inside the tank from the manufacturer).
2. Rinse the CIP tank and hoses with clean water to remove any debris or contamination after un-packing or after the CIP system has been in storage.
3. Install two of the long hoses into the upper ports on the tank by screwing the 1" pipe thread adapter that is on the end of the hose into the pre-mounted bulkhead fitting. Use two to three wraps of Teflon tape to aid installation and to seal the pipe threads.

4. Install the third long hose into the outlet of the pump (the outlet is the port facing upward on the pump).
5. Install the short hose (approximately 2' long) into the pump inlet (the port at the end of the pump that is facing horizontal).
6. Connect the pump inlet hose to the fitting at the bottom of the CIP tank using the cam-lock connector.
7. Turn off the MRO before connecting the CIP2 system or breaking any water lines.
8. Choose the correct fittings supplied with the CIP2 system that will mate to the INLET, REJECT, and PRODUCT ports of the reverse osmosis system to be cleaned, and install them.
9. Connect the CIP pump outlet hose to the reverse osmosis water INLET only.

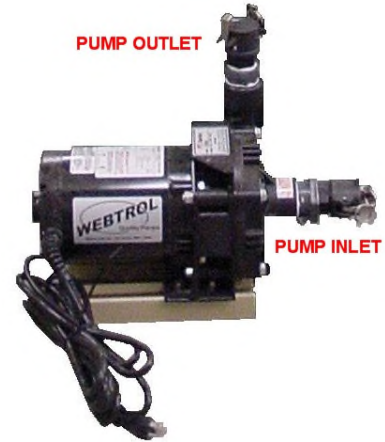

WARNING: If the **PRODUCT** hose (PERMEATE) is momentarily pressurized due to an incorrect connection (the CIP in reverse flow), the membranes will be destroyed.

NOTE: When connecting the CIP2 to an AmeriWater MRO 3, 4 or 5, the existing MRO hoses (one 3/4" hose and two 1/2" hoses) will need to be cut about 12" from the hose ends opposite the MRO. Install the Cam-Lock male/female connector pair using the included hose barbs and hose clamps. Be sure that the Cam-Lock connectors are "gendered" in such a manner that the hoses can be connected to the correct fittings on the CIP2 tank (see below).

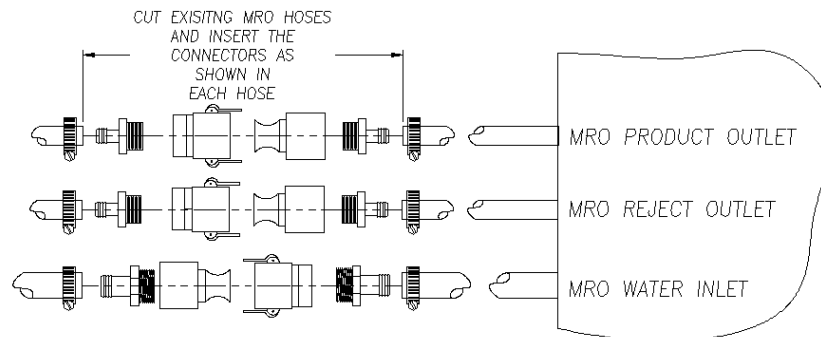

10. Connect the REJECT AND PRODUCT hoses to the CIP hoses near the top of the CIP tank (hoses may be connected in either orientation).
11. Verify that all connections are made and are watertight.

4. INSTALLATION DIAGRAM

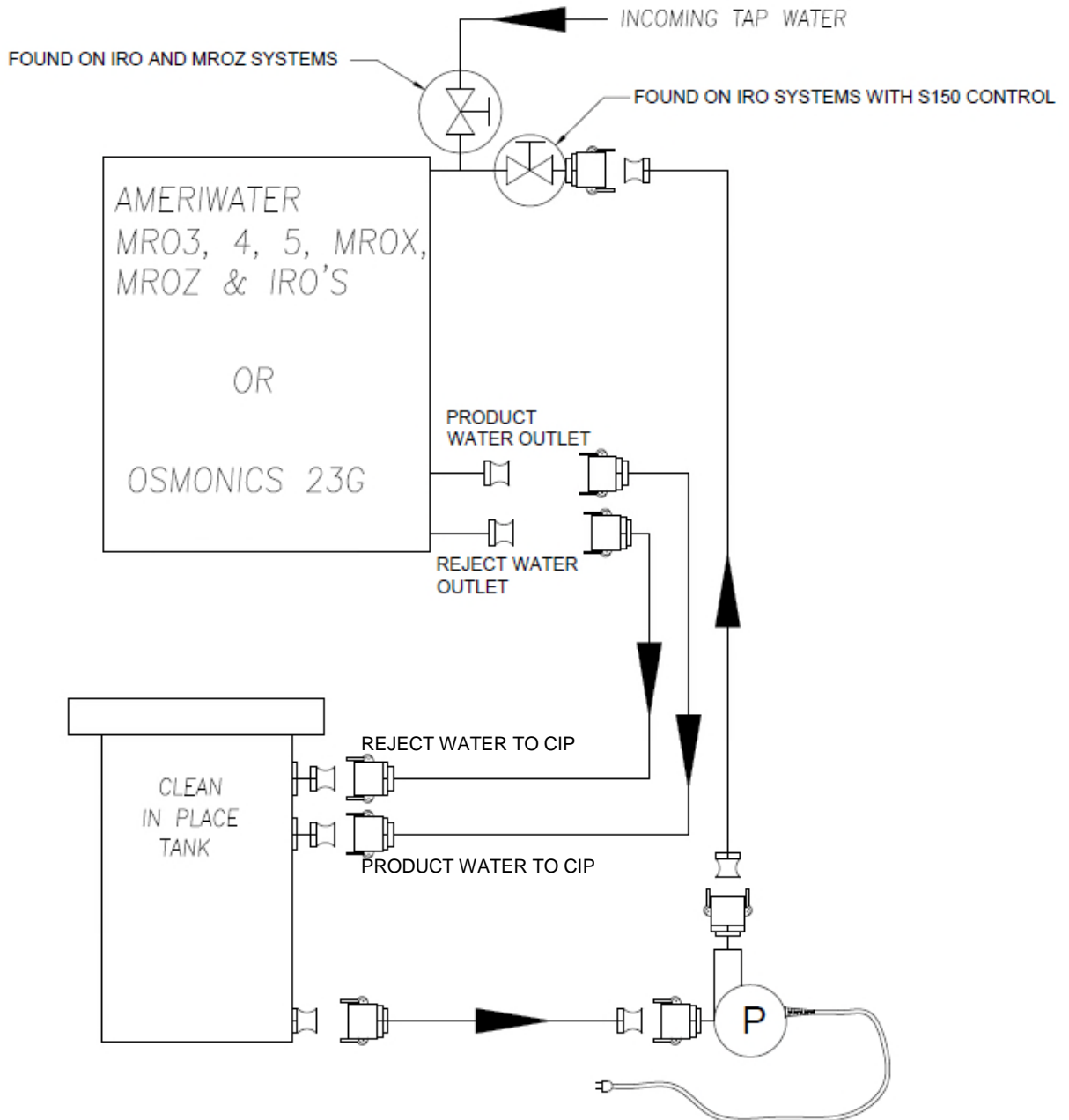

Fittings are provided to fit the AmeriWater MRO3, 4, 5, MROX & MROZ models, AmeriWater Industrial RO systems, and other common RO systems. Select the correct fittings (fittings included) to mate to the RO system at your facility.

MROZ Connection to CIP tank

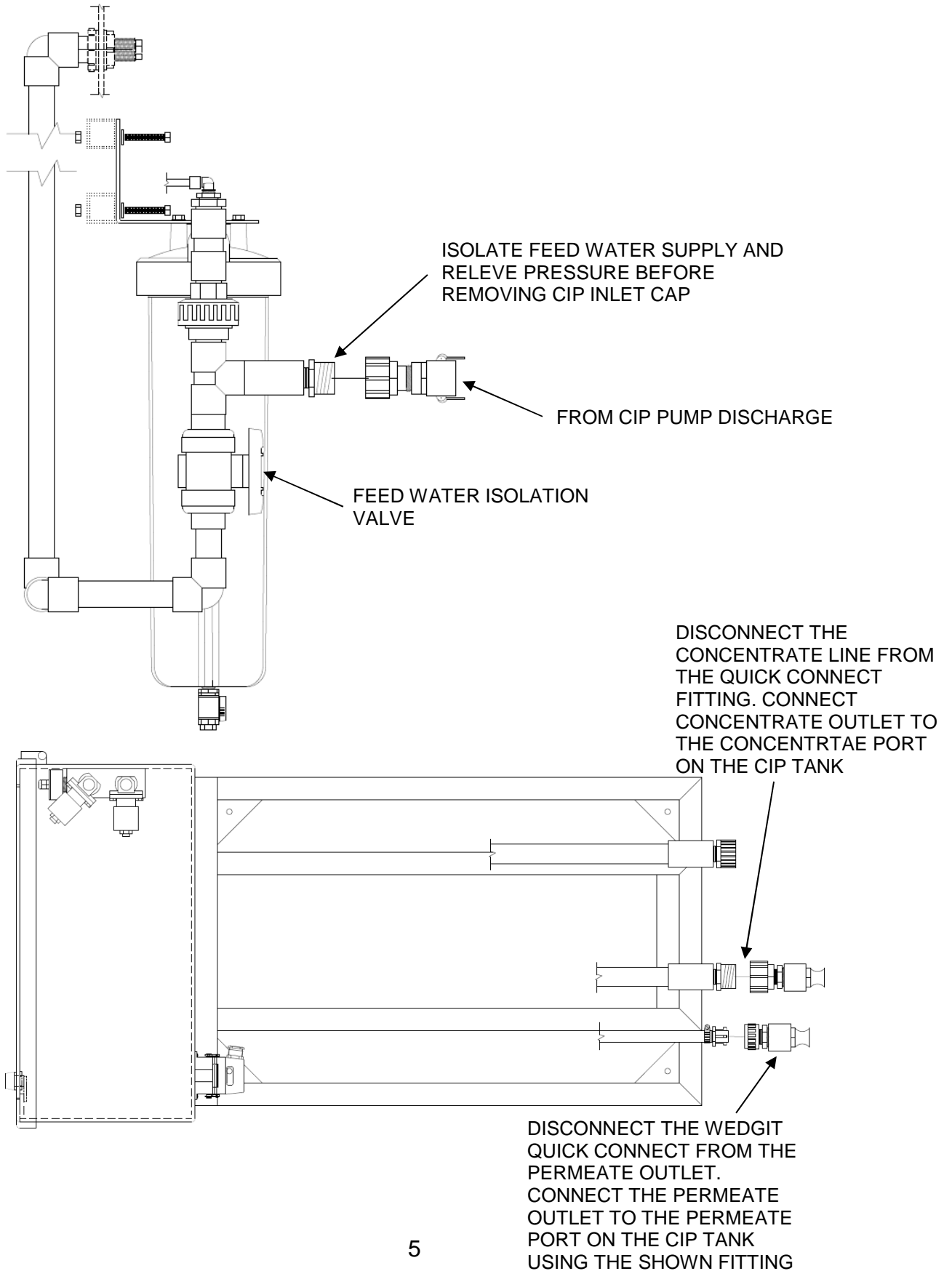

5. HIGH pH CLEANING

NOTE: Be sure to remove carbon block filters (if applicable) from the RO before performing cleaning. Filters will be clogged by cleaning solution if not removed. Sediment filter may remain in the system.

AmeriClean B is used first for the removal of biological and colloidal foulants.

CAUTION: Do not to allow any cleaning solution to enter the **PRODUCT** line going to the storage tank (if applicable).

1. Fill the CIP tank with RO product water (or softened water) to about 25" deep in the tank. Water at 25" deep in the tank is approximately 27 gallons. Water should be at or near 86°F for maximum cleaning effect.
2. Slowly add 3 lb (1,110 ml) [3 full bags] of **AmeriClean B** powder to the water in the cleaning tank.
3. Agitate the solution until the powder is completely dissolved. **It is important to make sure all of the powder is dissolved before continuing.**

WARNING: Wear appropriate eye and skin protection when handling the membrane cleaning chemicals. The cleaners are high and low pH chemicals and may cause severe chemical burns. Read the MSDS for further information.

4. Open the valves that are connected to the CIP INLET, PRODUCT, and REJECT hoses to permit flow from the CIP2 through the RO and back to the CIP2 only. The MRO should be turned off (STANDBY) at this point.
5. Connect the power cord of the CIP2 pump to a 120 VAC receptacle and allow the solution to begin circulating.
6. Remove the rear cover on the MRO.
7. There is a toggle switch on the backside of the controller. This switch allows the MRO to operate with the CIP2 connected without sending the system into an alarm condition. Move the toggle switch to the "ON" position.
8. Close the rear cover on the MRO.
9. Switch the Flush Valve on the RO from "Operate" to "Flush".
10. Turn on the MRO and verify that the cleaning solution is recirculating and flowing from the drain hose inside the CIP tank.
11. Allow the cleaning solution to recirculate for a minimum of 50 minutes.

- a. Depending on the nature of the fouling, a soak period may be necessary. If the membranes are not heavily fouled, proceed to step 11.
- b. In cases of heavy fouling, turn off the RO and CIP pump and allow the system to soak for a minimum of 30 minutes.*
* Contact AmeriWater Technical Support or your local AmeriWater dealer for custom cleaning procedures if necessary.
- c. After the soak time, turn on the CIP pump and RO, and allow the cleaning solution to recirculate again for 30 minutes.

12. Disconnect the pump outlet hose from the CIP tank and direct the hose to a drain. Continue running to drain until the CIP tank is empty (some solution may need to be manually dumped out of the CIP tank).

CAUTION: Neutralization of the spent cleaning solution may be required by local regulations. Verify the requirements of local regulations prior to emptying the cleaning solution into the drain. Use an approved waste container for chemical waste disposal if required.

13. After removing the spent chemical from the CIP2 tank, and with the CIP2 pump discharge directed to drain, turn on the MRO and allow fresh water to flow into and through the RO and CIP2 for 10 minutes or until the pH of the water at the pump discharge is neutral (between 6 and 8).
14. Proceed to the low pH cleaning.

WARNING: Never allow AmeriClean A and AmeriClean B to mix! Mixing the chemicals will cause an exothermic reaction which may result in serious injury and damage to the equipment! Flush the system thoroughly and verify the pH of the reject water is neutral prior to switching chemicals!

NOTE: The 20" filter housings may trap some left over chemical solution causing rinse out times to be high. To shorten the rinse time, remove and dump the filter housing, then reinstall in the system. This allows the housing to fill with fresh water and reduces time required for rinsing.

6. LOW pH CLEANING

AmeriClean A is used second for the removal of inorganic scale and metals.

1. Fill the CIP tank with RO product water (or softened water) to about 25" deep in the tank. Water at 25" deep in the tank is approximately 27 gallons. Water should be at or near 86 °F for the maximum cleaning effect.
2. Slowly add 3 lb (800 ml) [3 full bags] of **AmeriClean A** powder to the water in the cleaning tank.
3. Agitate the solution until the powder completely dissolves. **It is important to make sure all of the powder is dissolved before continuing.**

WARNING: Wear appropriate eye and skin protection when handling the membrane cleaning chemicals. The cleaners are high and low pH chemicals and may cause severe chemical burns. Read the MSDS for further information.

4. Connect the power cord of the CIP2 pump to a 120 VAC receptacle and allow the solution to begin circulating.
5. Turn the MRO on and verify that the cleaning solution is recirculating and flowing from the drain hose inside the CIP tank.
6. Allow the cleaning solution to recirculate for a minimum of 50 minutes.
 - a. Depending on the nature of the fouling, a soak period may be necessary. If the membranes are not heavily fouled, proceed to step 11.
 - b. In cases of heavy fouling, turn off the RO and CIP pump and allow the system to soak for a minimum of 30 minutes.*
- * *Contact AmeriWater Technical Support or your local AmeriWater dealer for custom cleaning procedures if necessary.*

 - c. After the soak time, turn on the CIP pump and RO, and allow the cleaning solution to recirculate again for 30 minutes.
7. Disconnect the pump outlet hose from the CIP tank and direct the hose to a drain. Continue running to drain until the CIP tank is empty (some solution may need to be manually dumped out of the CIP tank).

CAUTION: Neutralization of the spent cleaning solution may be required by local regulations. Verify the requirements of local regulations prior to emptying the cleaning solution into the drain. Use an approved waste container for chemical waste disposal if required.

8. After removing the spent chemical from the CIP2 tank. With the CIP2 pump discharge directed to drain, turn on the MRO and allow fresh water to flow into and through the RO and CIP2 for 10 minutes or until the pH of the water at the pump discharge is neutral (between 6 and 8).
9. Turn OFF the MRO and disconnect the CIP2 system from the RO.
10. Operate the machine as described in the flushing section of the IRO or MRO manual for at least one hour while the PRODUCT and REJECT hoses are still directed to the drain.

The cleaner is sufficiently flushed when the pH and PRODUCT conductivity are restored to normal service operating levels.

11. Press the POWER key on the front of the controller to put the unit into "STAND-BY"
12. Disconnect the electrical power and gain access to the rear of the controller to move the toggle switch to "OFF". This will allow normal fault alarms to be active.
13. Close the cover on the MRO and turn on the electrical power.
14. To return the MRO to "service", close the PRODUCT AND REJECT valves going to the CIP2, then, open the "IN-SERVICE" PRODUCT AND REJECT so that flow is routed as intended in the "IN-SERVICE" mode. The CIP INLET valve should have already been closed in step 9.
15. Cap or plug the fittings on the RO that were used to connect to the CIP2 accordingly.
16. At this point the RO is ready to be turned on and operated. Press the POWER key to start the RO and monitor all the connections to be sure there are no leaks.
17. Monitor the RO output and verify that conductivity is within specified range.
18. Drain the CIP2 system of residual water, place the hoses and pump back into the tank, and move the CIP2 system to a place for storage until the next use.

WARNING: DO NOT connect the MRO to the point of use and/or place the MRO in service until the Product Water conductivity remains below the setpoint and is not in alarm! Serious injury or illness to the patient may result!

7. AMERI WATER IRO SPECIFIC INSTRUCTIONS

1. Close the PRODUCT, REJECT, and INLET valves to prevent incoming water from flowing into the RO or allowing water to flow out of the normal discharge hoses for PRODUCT WATER or REJECT WATER.
2. Turn OFF the power disconnect prior to opening the controller.
3. After placing the CIP Switch in the ON position, close the controller door and turn on the power disconnect.
4. Complete the High pH and Low pH cleaning steps.

8. SPARE PARTS LIST

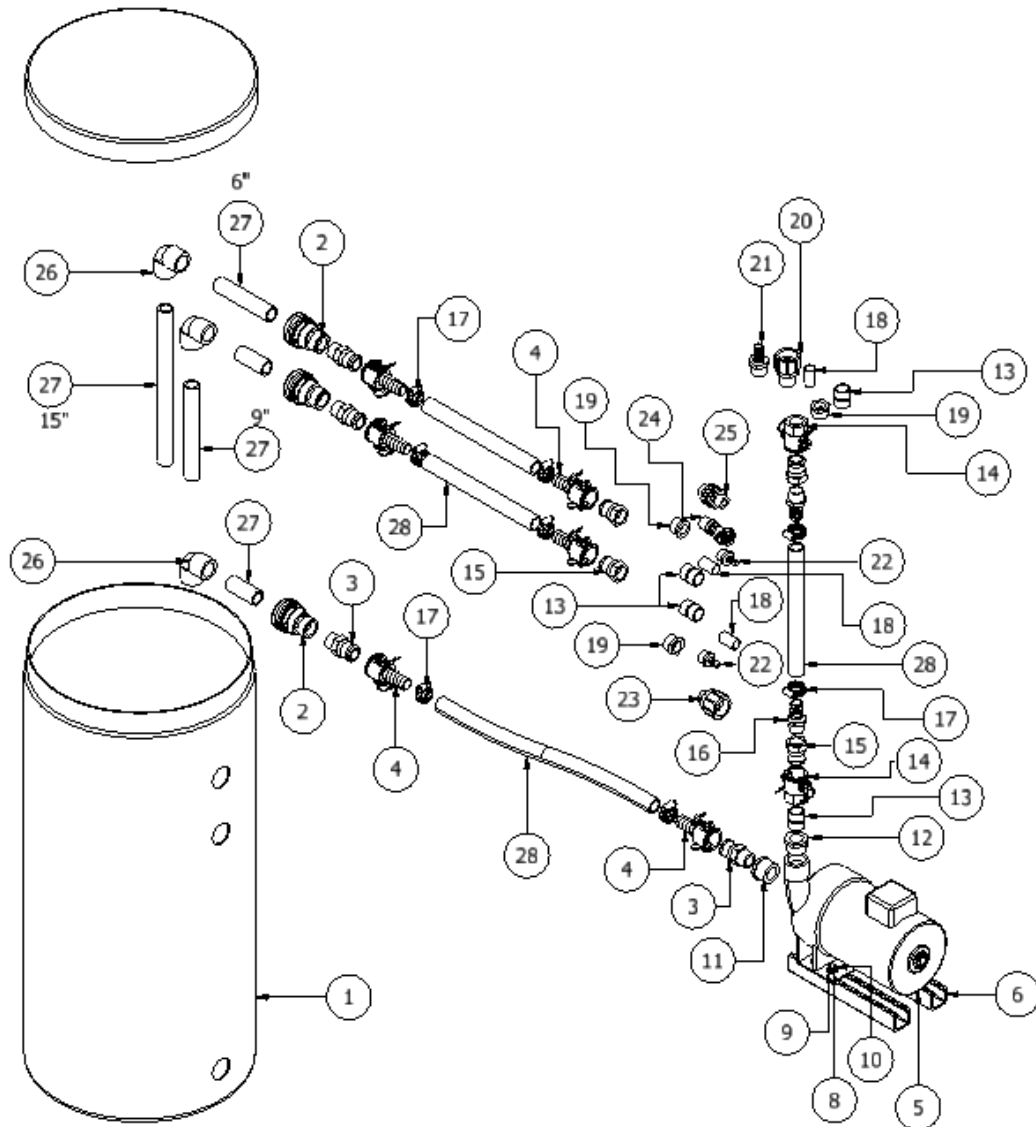

See parts list on next page for replacement part numbers.

ITEM	PART NUMBER	DESCRIPTION
1	30550421	TANK BRINE 18 X 40 BLACK w/ LID
2	041531839	BULKHD,1,TXS,PVC80
3	16-0037	Q-Con, 1.0 NPT Male X Male Insert, Polyglass
4	16-0036	Q-Con, 1.0 Coupling X HB, Polyglass
5	80510906	PUMP WEBTROL PC50R-1/2HP
6	91730086	Unistrut, 1.625 Fiberglass PE
7	91730212	UNST,SPRING NUT,.38,PLTD
8	92-0041	Washer,Flat,3/8IN.,SS, HD
9	93730123	WASHER LOCK 3/8IN. SS
10	92730235	BOLT,3/8-16x1,HEX HD,SS
11	041617151	BUSH,1.5X1,THRD,PVC80
12	041567001	BUSH,1.25x1,THRD,PVC80
13	041720151	NIPPLE,1XCL,PVC80
14	16-0041	Q-CON,1 IN CL,COUPxFPT,SS,POLYGLASS
15	16-0040	Q-CON,1 IN CL,INSx1IN FPT,POLYGLASS
16	14520215	Adapter 1.0 Male NPT X 1.0 HB, PP
17	15650100	CLAMP,HOSE,1,SST
18	041531829	NIPPLE, .75 X CL, PVC80
19	046530953	Bush, 1.0 X 0.75 THRD, PP
20	16UMA100	Q-CON,COUP THD STEM x1 FEM THD,STRUCT
21	14531145	Adapter 1.0 NPT Male X 0.75 HB, PP
22	14520509	Adapter 0.75 NPT Male X 0.5 HB, PP
23	16-0025	Q-CON,COUP THDx.75THD,STRUCT
24	16521116	Q-Con, 0.75 NPT Male, CPC Body, PS
25	16521110	Q-CON,WEDGIT,THRDXTHRD,PAIR
26	041720167	EL,1,SOC,PVC80
27	021720170	PIPE,1",PVC80
28	12677135	HOSE,MEDICAL,1",STYLE 5000
29*	14520506	HOSEBARB, 1/2"MPT x 1/2"HB
30*	15650050	CLAMP HOSE 1/2" SST
31*	15650075	CLAMP HOSE 3/4" SST
32*	16-0038	Q-CON, 1"CL, CAP
33*	16-0039	Q-CON, 1"PLUG
34*	37-0004	AMERICLEAN A (Sold in 10 lb case)
35*	37-0005	AMERICLEAN B (Sold in 10 lb case)

*Items not shown in exploded diagram