

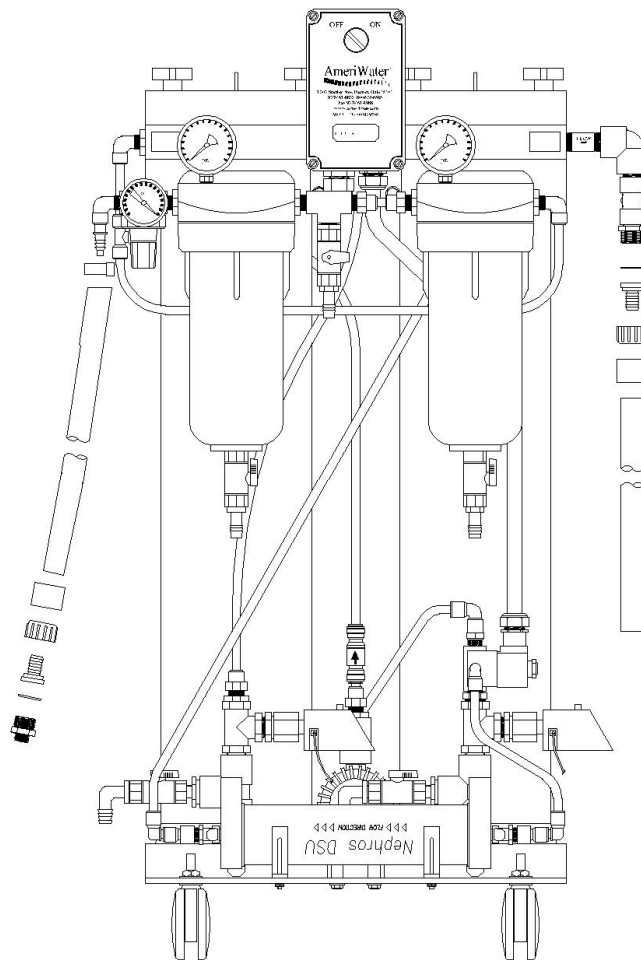

SILEX

DEIONIZER FOR DIALYSIS OPERATION & MAINTENANCE MANUAL



**Manufactured With Pride
In The USA**

www.amerewater.com • 800-535-5585

AmeriWater • 3345 Stop 8 Rd • Dayton, OH 45414

WARNING: When used as a medical device, Federal Law restricts this device to sale by or on the order of a physician.

WARNING: The entire Operation and Maintenance Manual should be read before placing the Silex Deionizer in service. Failure to do so may result in serious personal injury and / or injury and illness to the patient.

WARNING: It is required that deionizers be preceded by an activated carbon absorption bed and followed by a bacteria and endotoxin filter.

Contents

1. YOUR SILEX SYSTEM	1
1.1. HOW DOES THE SILEX DEIONIZER WORK?	1
1.2. HOW DOES THE REGENERATION WORK?	1
1.3. ABOUT THE RESIN PACK.	1
2. SILEX FEATURES	2
3. INSTALLATION IN 10 EASY STEPS	3
4. MONITORING	8
5. RESIN PACK & FILTER EXCHANGE	9
5.1. RESIN PACK EXCHANGE	9
5.2. FILTER CARTRIDGE & NEPHROS FILTER CAPSULE REPLACEMENT	12
6. RESIN PACK REGENERATION	13
7. SERVICING YOUR SILEX SYSTEM	14
7.1. DISINFECTION	14
8. SPARE PARTS LIST	16
9. TROUBLESHOOTING FOR THE ECOCIRC PUMP	17
9.1. PUMP COMPONENTS	17
9.2. PUMP DOES NOT RUN	17
9.3. LOUD FLOW NOISE	17
9.4. CLEANING THE PUMP – CHANGING THE ROTOR	18
10. WARRANTY POLICY	19

1. YOUR SILEX SYSTEM

1.1. How does the Silex Deionizer work?

This Silex system is designed to provide purified water that meets or exceeds AAMI product water quality requirements for water used to prepare dialysate or concentrates in a dialysis facility. The facility's tap water first passes through a regulator to maintain the feed pressure at 50 psi (pounds per square inch) or less. The tap water then passes through (2) 10" ChlorPlus carbon block filters that removes chlorine, chloramines, and particulates. The filtered water enters the first deionizer column (worker) where the deionizer resin removes chemical contaminants from the water through an ion exchange process. A resistivity light, set at 50K Ohms, monitors the water exiting the worker column as it travels into the second column (polisher). As it leaves the polisher, the purified water passes through a 1 Meg-Ohm resistivity monitor with alarm, followed by a normally closed solenoid valve which stays closed with a signal of alarm. The solenoid valve is followed by a Nephros Dual Stage Ultra-Filter Capsule that removes a spectrum of bacteria, viral agents and biological toxins (including endotoxin) down to required levels. The water then travels to the point of use. This unit utilizes an Ecocirc Pump that is used for recirculating the water back through the Silex system.

1.2. How does the regeneration work?

The ion exchange capacity of the resin packs used in the Silex system will eventually exhaust. AmeriWater's regeneration center maintains the resin used in the Silex Deionizer. When resin packs are exhausted, simply replace the packs in the Silex system with new resin packs and return the exhausted packs to AmeriWater for regeneration. The resin will be regenerated in our GMP/QS regeneration facility and returned within one week.

1.3. About the resin pack.

The resin packs contain mixed bed resin contained in a polypropylene bag that never has to be opened. Resin packs are shipped in plastic sleeves to prevent the exchangers from drying out and to protect them from contamination. They have a shelf life of approximately six months.

CAUTION: Return resin packs stored for more than six months to AmeriWater for regeneration. DO NOT use resin packs that have been stored for more than six months.

2. SILEX FEATURES

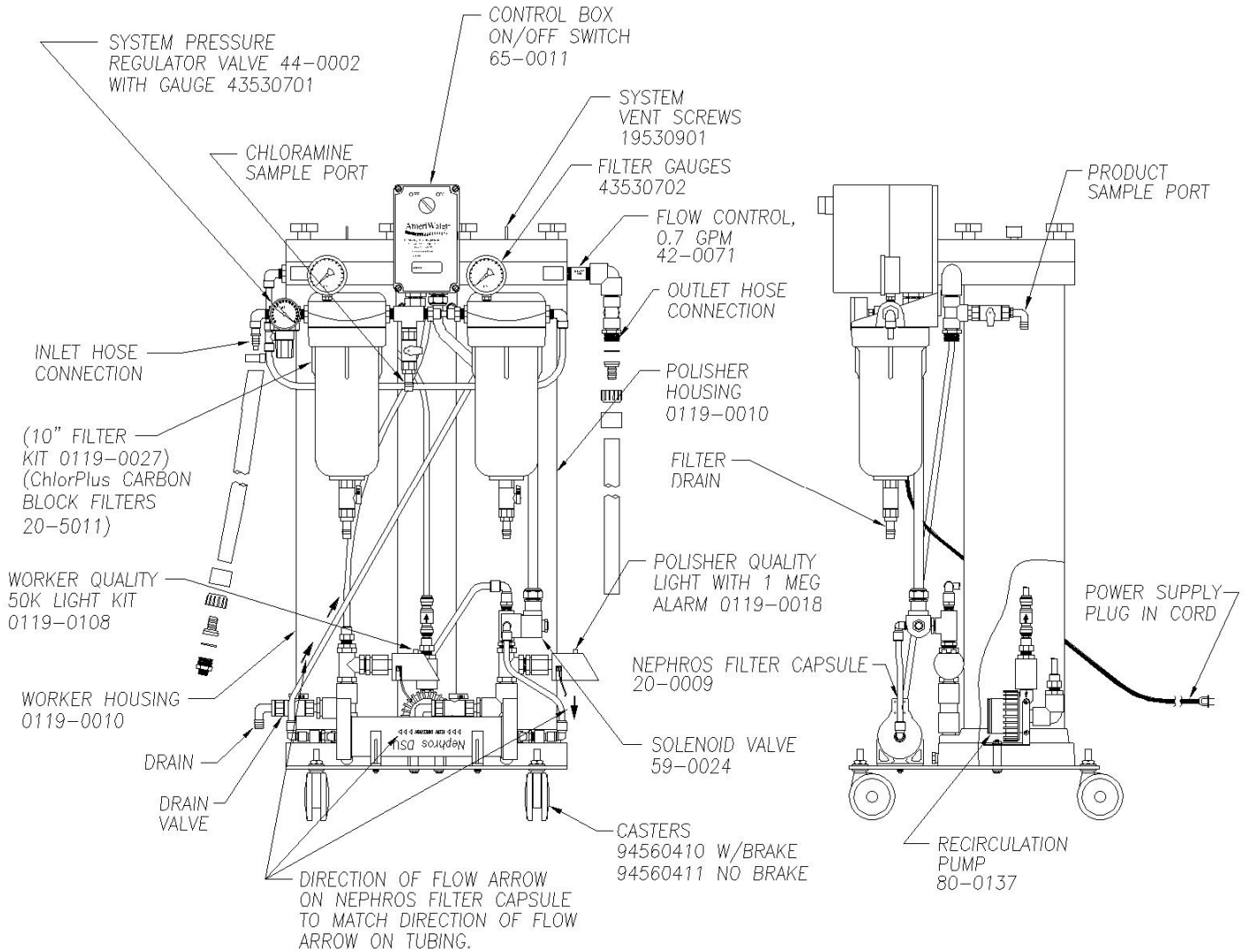

3. INSTALLATION IN 10 EASY STEPS

CAUTION: The Silex Deionizer is designed to operate at pressures up to 50 PSI (Pounds per Square Inch). Operating the system at pressures greater than 50 PSI may result in damage to the system and personal injury!

1. Locate the Silex system on a firm, level foundation.
2. It is recommended, but not required, to locate the system near a standard floor drain or sump and a 115 volt receptacle. If a drain is not feasible, the system can be drained into a container. The receptacle is where the power supply cord will be plugged in. The ON/OFF switch on the control box should be set at OFF. The switch will activate the pump, the worker quality light, the polisher quality light and the solenoid valve. There must be water through the Silex system before turning the switch to the ON position. A green light located on the switch also indicates that the unit is on. Attention: running the pump dry may cause premature failure.
3. It is recommended to install shut-off valves on the inlet side of the unit to facilitate changing of resin packs.
4. Connect the inlet supply hose to the hose barb fitting on the left side of the system (while facing the label). Use the hose clamps provided with the system to secure the hose to the hose barb fitting.

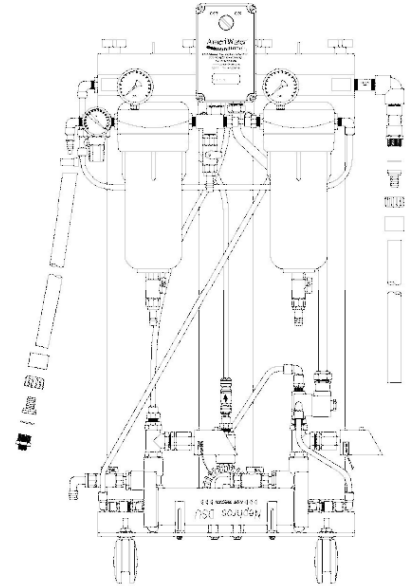

NOTE: 16 feet of hose has been provided with the Silex system. Cut the hose to the desired lengths for the inlet hose and outlet hose and install the provided fittings as needed. (See drawing)

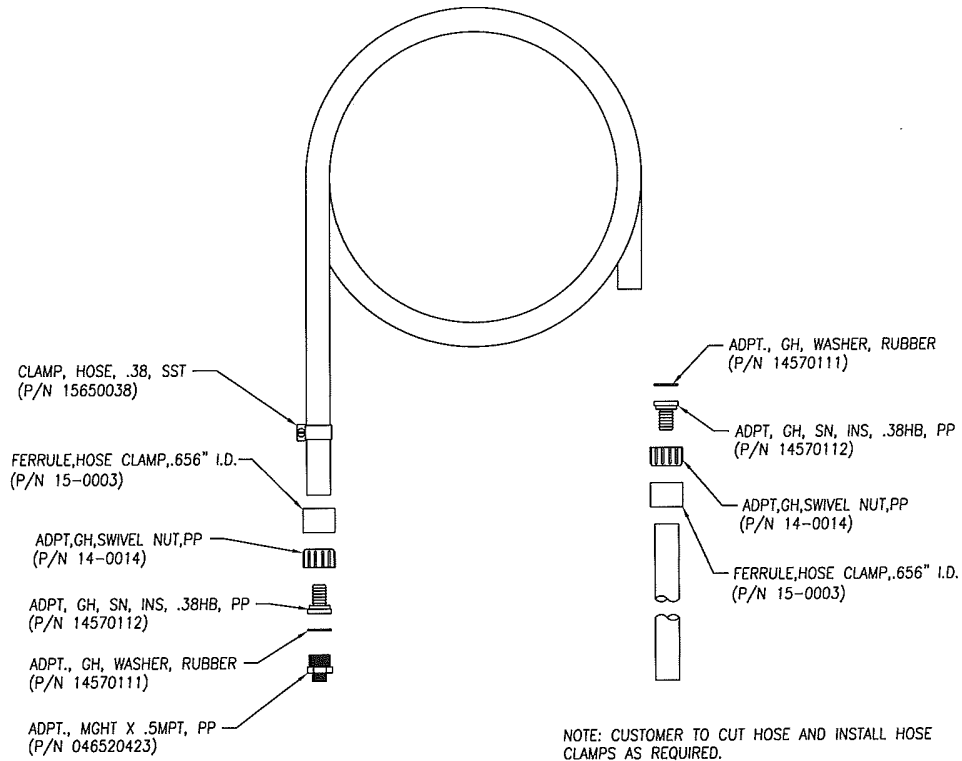

5. Connect the outlet hose to the male garden hose thread adaptor on the right side of the system (while facing the control box and label). Use the swivel adaptor nut, garden hose adaptor, garden hose adapter washer and the ferrule hose clamp provided with the system to secure the hose.
6. Disinfect the system prior to installing the components. See section 7.1 for complete instructions.
 - a. The ON/OFF switch on the control box should be set at OFF. Turn off the water supply to the Silex system.
 - b. Pour 5 oz (150 mL) of PAA (such as Peracidin or Minncare) into each pre-filter sump as well as each Silex column.
 - c. Close all drain valves, sample ports, and filter drains and open the air vents located in the center of the top plates.

- d. Turn on the water supply to the Silex system and allow the system to fill with water until the presence of PAA can be detected at the outlet of the system. Verify the concentration of PAA at the outlet using a high level concentration PAA test strip (P/N 97HP20401).
 - e. Turn off the water supply to the Silex system and allow the system to soak for 1 hour.
 - f. After the soak time, drain the water out of the system by placing a container under the drain valves and opening the valves. Open the filter sump valves.
 - g. Turn on the water supply to the system. Allow the system to flush until PAA is no longer detected. (Use low-level PAA test strips, P/N 97PX20501, to test for residual PAA).
 - h. Place the container under the filter drains and open the valves to drain the water out of the filter sumps.
 - i. Close all valves when water is no longer flowing out of them.
7. Install the ChlorPlus carbon block filter in both of the filter housings.

8. Install the resin pack(s):

- a. Lock the front wheels. Remove the cover plates by unscrewing the four black knobs on each plate. To break the seal between the cover plates and the upper plates, use a slotted screw driver in the pry notch located in the top of each upper plate. Open the drain valve at the bottom of each column.



- b. Remove the resin pack from the shipping box and open the tied end of the plastic sleeve. **DO NOT** remove the resin pack from the plastic sleeve at this time.



- c. Stretch the resin pack over your arm to elongate the pack, and feed it into the Silex column allowing the pack to slide out of the plastic sleeve. Save the plastic bag for future exchange.



- d. Verify that the O-ring is clean and in place and replace the cover plates. Tighten the black knobs evenly by turning the knobs at opposite corners at the same time. Repeat for the other two corners.



CAUTION: Failure to tighten the knobs completely may cause the cover plate to separate from the system when pressurized.

- e. Close the drain valve at the bottom of the column.
- f. Repeat steps a. through e. for each of the columns.

9. Open the air vents located on the top of the cover plates and turn on the water supply. Tighten the air vents closed when water begins to escape through the vents.
10. Allow water to flow through the Silex system chloramine port for 5 minutes. Turn the ON/OFF switch on the control box to ON. Continue running water through the system until the water quality lights change from red to green. The green lights indicate that the Silex is producing deionized water.



Dialysis machine should be placed in rinse during start up of the Silex system until both resistivity monitors indicate a green light. If either light does not indicate green after a period of 10 minutes, change the resin packs and repeat the rinsing process.

WARNING: Always allow the system to rinse up to quality prior to placing in service. Failure to do so may result in patient injury or illness.

CAUTION: DO NOT attempt to open the cover plates while the system is pressurized or severe injury may occur! Always turn off the water supply, open the air vents, and drain the water out of the system prior to opening the cover plates.

4. MONITORING

AmeriWater recommends the following monitoring guidelines to ensure ongoing quality of the water produced by the Silex Deionizer System.

Item to Monitor	What to Monitor	Normal Interval	Specification	Action when out of specification
Product water at chloramines sample port	Product water free of total chlorine	Prior to each treatment	< 0.1 mg/L of total chlorine	Replace the carbon block filter
Pressure regulator gauge	Regulated feed water pressure	Daily	≤ 50 psi	Adjust the pressure regulator to 50 psi or less
Worker quality light (50K light)	Worker product water resistivity	Continuous	Light green > 50K Ohms	Exchange the resin packs if light is red. Terminate treatment immediately if polisher light is red.
Polisher quality light (1 Meg light)	Final product water resistivity	Continuous	Light green > 1 Meg-Ohm	Terminate treatment immediately if light is red and exchange resin packs.
Endotoxin filter (Nephros filter capsule)	Flow rate	Daily	Drop in flow rate	Replace the endotoxin filter (Nephros filter capsule)
Product Water	Bacterial cultures & endotoxin in LAL	Monthly	Bacterial count ≤ 50 CFU/mL; endotoxin ≤ 1 EU/mL	Terminate treatment immediately, disinfect the system; exchange resin packs and filter cartridges.
Product Water	Chemical analysis	Annual	AAMI RD52 4.1.1 (Table 1)	Terminate treatment immediately and exchange resin packs

WARNING: Terminate treatment immediately if product water total chlorine is greater than 0.1 mg/L or if product water quality drops below the 1 Meg-Ohm set point. Serious injury or illness to the patient may result!

5. RESIN PACK & FILTER EXCHANGE

5.1. Resin Pack Exchange

1. Lock the front wheels. Turn the ON/OFF switch on the control box to OFF. Turn off the water supply to the system and place a container under the drain valves located on the bottom plates of the system. Open the valves and allow the water to drain into the container.



2. Do not open the cover plates while the system is pressurized. Always turn off the water supply, open the air vents, and drain the water out of the system prior to opening the cover plates.



3. Remove the cover plates by unscrewing the black knobs located at each corner of the cover plates.



4. Pull the exhausted resin pack part of the way out of the column and lay it over the top of the system.

NOTE: If the drain valve located on the bottom plate is not open, a vacuum will be created making it difficult to remove the resin pack.



5. Slowly pull the exhausted resin pack over the side of the column while sliding it out of the column and into the plastic bag that it was shipped in. Return the exhausted resin pack to AmeriWater for regeneration.



6. Remove the new resin pack from the shipping box and open the plastic bag being careful not to touch the resin pack. Stretch the resin pack over your arm to elongate the pack. Feed the pack into the column allowing it to slide out of the plastic bag. Save the plastic bag for the next resin pack exchange.



7. Replace the cover plate and tighten the knobs. To ensure proper tightening and a good seal, tighten the knobs in opposite corners simultaneously and then tighten the knobs in the remaining corners.



CAUTION: Failure to tighten the knobs completely may cause the cover plate to separate from the system when pressurized.

8. Close the drain valves and turn on the water supply. Release trapped air from the Silex system by loosening the air vent screws (located in the center of the cover plates).

- a. Tighten the Air Vent Screws when water begins to flow from the air vents. This ensures that all of the air has been removed from the system and maximizes the life and efficiency of the resin packs.



NOTE: Vent the system after every resin pack exchange to maximize the life and efficiency of the resin packs.

9. Turn the switch on the control box to ON. Run the system until the 2 indicator lights turn green before placing in service. This will ensure that good quality water will be entering the dialysis machine.

WARNING: Always allow the system to rinse up to quality prior to placing in service. Failure to do so may result in patient injury, illness, or death! NEVER place the Silex system in service if the quality light/alarm indicates poor quality water!

5.2. Filter Cartridge & Nephros Filter Capsule Replacement

Carbon block filter cartridges should be replaced when the chloramines sample indicates total chlorine greater than 0.1 PPM. This sample is to be taken after the system has been allowed to run for a few minutes while flushing the water through the chloramine sample port.

The Silex system is equipped with pressure gauges on the filter housing, both filter cartridges should be exchanged when the differential pressure is greater than 10 psi (**P**ounds per **S**quare **I**nch).

1. Turn the ON/OFF switch on the control box to OFF. Turn off the water supply to the system.
2. Place a container under the filter housing sumps and open the filter drain ports on the bottom of the sumps to drain the water out of the filter housing. Close the filter drains when water ceases to flow out of them.
3. Use the filter wrench supplied in the installation kit to turn the filter housing counterclockwise.
4. Remove and discard the old filter cartridge(s).
5. Partially unwrap the plastic from the new filter cartridge. Holding the end covered in plastic, place the new filter cartridge in the housing. Discard the plastic wrapper after installation.
6. Thread the filter housing back on making sure the O-ring is in the groove and is not pinched.

The Endotoxin filter (Nephros filter capsule) is expected to last up to approximately 12 months. To change this filter, first follow steps 1 & 2 for the filter cartridges. Disengage the Nephros filter capsule from the system by pushing the button on each quick-connect, on either end of the filter (SEE BELOW FIGURE) and lifting the filter from the (2) mounting brackets. The arrow tape on the tubing indicates the flow of the water. The arrows on the filter, which indicate direction of flow, should match the tubing flow arrows direction. To connect the new filter to the system, place the filter in the mounting brackets, make sure that the direction of flow is correct and connect the outlet of the filter followed by the inlet. Turn the water supply on followed by the power switch on the Silex and flush the system to drain for ~10 min to ensure no air is trapped in the Nephros DSU filter.

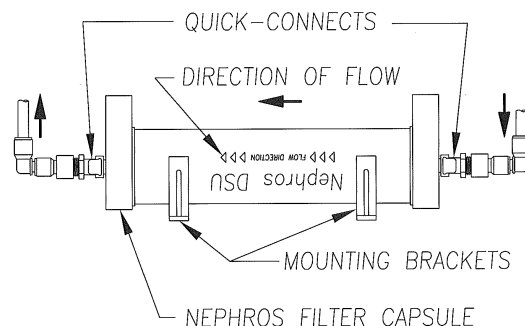

6. RESIN PACK REGENERATION

Regeneration certificates are used to simplify the exchange of your exhausted Silex system packs. The certificate has been purchased and will be used as payment for the resin pack regeneration service. Simply follow these steps:

Fill out a regeneration certificate by printing your name, phone number, company and address.

1. Work with your dialysis provider for this process.
2. Fill out a regeneration certificate by printing your name, phone number, company and address.
3. When you send each pack to AmeriWater, enclose the regeneration certificate in the box. AmeriWater will ship you a freshly regenerated resin pack.
4. To order more certificates, contact the company that originally sold you the deionizer.
5. It is recommended to send the exhausted resin to AmeriWater immediately after exchange. This will allow time for shipment and will maintain your uninterrupted supply of deionized water.

Certificates Make Exchanging Packs a Breeze!

AmeriWater®

Resin Regeneration Certificate

This certificate has been purchased and will be used as payment for the resin pack regeneration service.

When you send each pack to AmeriWater, enclose this regeneration certificate in the box. AmeriWater will ship you a freshly regenerated resin pack. To order more certificates, contact the company that originally sold you the deionizer.

Fill out for return shipment to:

Name _____
Phone (_____) _____
Company _____
Address _____
Address _____
City _____
State/Zip _____

www.amerewater.com **415865** **45101C Ultra Pure Resin Pack**

Ship exhausted pack and certificate to:
AmeriWater Inc.
1257 Stanley Ave.
Dayton, Ohio 45404

Fill out and enclose in box for return shipment

- NO Paperwork
- NO Phone Calls
- NO Purchase Orders

7. SERVICING YOUR SILEX SYSTEM

7.1. Disinfection

It is recommended that the Silex system be disinfected monthly to assure continuous high-quality product water. To efficiently and quickly disinfect the system, follow these easy steps: **NEVER ALLOW THE RECIRCULATION PUMP TO RUN DRY.**

- a. Turn the ON/OFF switch on the control box to OFF. Turn off the water supply to the Silex system.
- b. Remove the carbon filter as well as the resin packs from the system. Ensure that the endotoxin filter (Nephros filter capsule) is left in.
- c. Pour 5 oz (150 mL) of PAA (such as Peracidin or Minncare) or chlorine (5% sodium hypochlorite, household bleach) into each filter sump as well as each Silex column.
- d. Reinstall the filter sumps and both cover plates. Close all drain valves, sample ports, and filter drains and open the air vents located in the center of the top plates.
- e. Turn on the water supply to the Silex system and allow the system to fill with water. Close the air vent once water begins to seep out of the top of the column.
- f. Once the system is full of water, turn the power switch to “ON” and remove the power cord from the **Polisher Quality Light** so water can pass the solenoid valve. Leave the water supply on until the presence of chlorine can be detected at the outlet of the system. Verify the concentration of disinfectant at the outlet of the system. Verify the concentration of disinfectant at the outlet using a high level concentration test strip (P/N 97HP20401 for PAA or P/N 97RC22101 for chlorine).
- g. Turn the power switch to “OFF” to shut the pump off preventing excessive wear. Turn off the water supply to the Silex system and allow the system to soak for 1 hour.
- h. After the soak time, drain the water out of the system by placing a container under the drain valves and opening the valves. Open the air vents on the top of the columns.
- i. Open the drain valves on the carbon block filter bowls and allow them to drain completely. After the water has completely drained, remove the bowls and dump out any remaining water to ensure all disinfectant is removed from the system before flushing.

- j. Close all drain valves, sample ports, and filter drains and ensure the air vents located in the center of the top plates remain open before turning the water supply on.
- k. Turn on the water supply to the system. Allow the system to fill with water. Close the air vents when water begins to seep out. Turn the power switch to “ON” and be sure the power cord for the **Polisher Quality Light** is still disconnected.
- l. Allow the system to flush until the disinfectant is no longer detected at the outlet. (Use low-level test strips P/N 97HP20401 to test for residual PAA or P/N 97CM20201 to test for residual chlorine).
- m. Once disinfectant is no longer detected anywhere in the system, turn the power switch to “OFF” and drain the water from the system by opening all of the drains. Close drains once the water stops draining from the system.
- n. Follow the Resin Pack + Filter Exchange instructions to replace the resin packs and carbon block filters. Reinstall the power cord to the **Polisher Quality Light** to complete the disinfection.

WARNING: **DO NOT place the system in service until a negative result for chlorine is achieved at the outlet hose! Serious injury, illness, or death to the patient may result!**

Apart from regular resin pack and filter exchange, and periodic disinfection, the Silex system requires no maintenance. In the event that the system is damaged, all parts can be ordered from AmeriWater by calling 1-800-535-5585.

8. SPARE PARTS LIST

Part Name	Part Number	Part Name	Part Number
Pressure Regulator Valve	44-0002	Pressure Gauge	43530701
System Vent Screw	19530901	Filter Gauge	43530702
Replacement Filter Cartridge 10"	20-5011	Replacement Nephros Filter Capsule	20-0009
Caster with Brake	94560410	Caster without Brake	94560411
Worker Quality Light Check 50K	75679121	Polisher Quality Light 1 Meg W/Alarm	75679117
Column O-Ring	19300001-00	Hose Clamp	15650038
Hose	12677138	Resin Pack	45101C
PAA High Level Concentration Test Strips	97HP20401	RenalCheck, Residual Peroxide Test Strips	97PX20501
Water Check RC Chlorine 0.5-1.0-500 (1%) Test Strips	97RC22101	Water Check 2 Low Level Chlorine / Chloramine	97CM20201
Replacement Kit, Wheel Mounting Plate	0119-0016	Recirculation Pump	80-0137
Solenoid Valve 2-Way Normally Closed 0-60 PSI 12VDC	59-0024		

9. TROUBLESHOOTING FOR THE ECOCIRC PUMP

9.1. Pump components

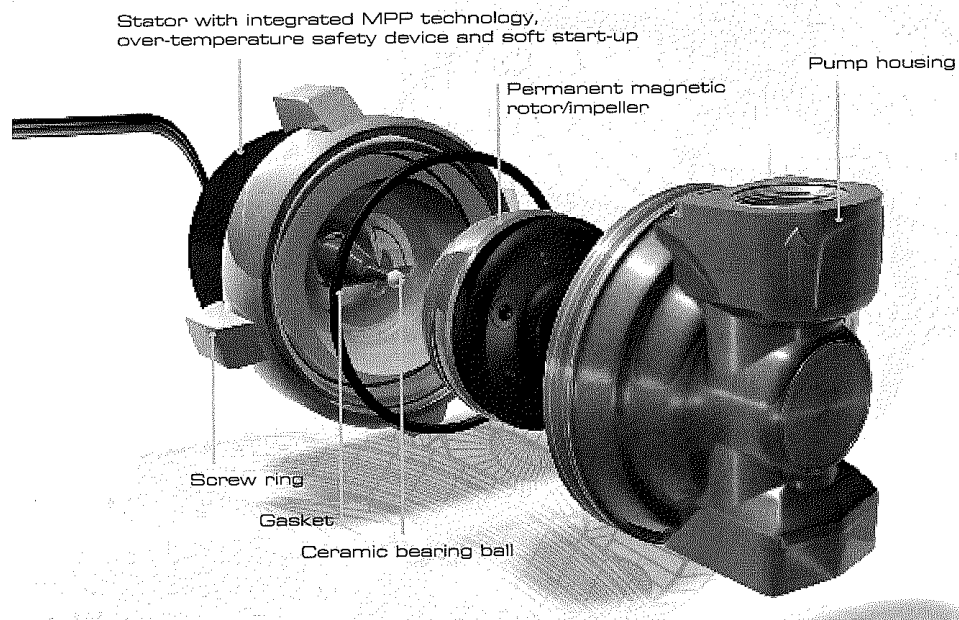

9.2. Pump does not run

Check if the voltage is correct. If voltage is correct, and the pump is hot, the thermal overload protection might have switched-off the pump. Wait until the pump is cooled again. It will turn on automatically.

The pump is blocked – clean the pump of impurities (The pump must be without power. Turn the ON/OFF switch on the control box to OFF. Close the shut-off valves. Open the screw ring carefully and clean the pump. Attention: water will run out of the pump, avoid electric parts getting wet).

The pumped fluid is too hot. (Make sure the pumped fluid temperature is within the allowed range of the temperature) Max. Ambient Temperature: 50 Degrees C

9.3. Loud flow noise

The system has not been purged correctly. Re-purge the system. Flush the system to remove dirt. Make sure the system is filled and the air has been forced out. The pump must be without power to rid the system of air. Turn the ON/OFF switch on the control box to OFF. Remove the screw ring from the pump a little, so that the air can leak out of

the pump. Attention: Avoid electric parts getting wet! Then open the lead-in carefully, until some water runs out of the pump. Now fasten the screw ring. The pump can be switched on. If you hear air noises at first, these should lessen after a short while. Turning the pump off and back on accelerates the air removal. If the air noise does not disappear or at least decrease substantially, reurge the system. Avoid dry run in any case! This will damage the pump. Be sure there is water throughout the system.

There might be dirt inside the pump housing. Clean the pump inside (The pump must be without power. Turn the ON/OFF switch on the control box to OFF. Close the shut-off valves. Open the screw ring carefully and clean the pump. Attention: water will run out of the pump, avoid electric parts getting wet).

9.4. Cleaning the pump – changing the rotor

The pump must be without power. Turn the ON/OFF switch on the control box to OFF. Close the shut-off valves. Open the screw ring carefully. Attention: water will run out of the pump. Avoid electric parts from getting wet or water running over the motor. Take away the stator. Take out the rotor carefully by grabbing it at the blade wheel. Check the pump housing, the rotor and the stator for impurities and remove them. Clean the pump.

Put the rotor back in the stator and check whether it can be turned easily. If not, the bearing might be worn (swirl marks on the bottom side of the rotor). Put in the new rotor. Change the pump against a new one. If the rotor can be turned easily, close the pump again. Remove the gasket. Clean the gasket and the nut and the area on the stator where the gasket lays. Put the gasket back inside the pump housing. Assemble the stator with the screw ring. The screw ring must not be installed using tools. Normally it is enough to assemble the screw ring manually. If the pump does not work, replace the motor.

10. WARRANTY POLICY

The buyer has a lifetime warranty on the PVC housing and a one year warranty on all other equipment and parts, excluding non-durable components (e.g., resin packs, filter cartridges, and water quality monitors); provided that the system is not subject to abuse, misuse, alteration, neglect, freezing, accident or negligence; and provided further that the system is not damaged as the result of any unusual force of nature such as, but not limited to, flood, hurricane, tornado or earthquake.

The warranty covers the replacement of equipment and/or parts only. The warranty does not cover labor charges or travel expenses resulting from the service of equipment. The manufacturer is excused if failure to perform its warranty obligations is the result of strikes, government regulation, materials shortages, or other circumstances beyond its control.

To obtain warranty service, notice must be given to AmeriWater within 30 days of the discovery of the defect.

There are no warranties on the SILEX system beyond those specifically described above. All implied warranties, including any implied warranty of merchantability or of fitness for a particular purpose are disclaimed to the extent they might extend beyond the above periods. The sole obligation of the manufacturer under these warranties is to replace or repair the component or part which proves to be defective within the specified time period, and the manufacturer is not liable for consequential or incidental damages. No dealer, agent, representative, or other person is authorized to extend or expand the warranties expressly described above.

Some states do not allow limitations on how long an implied warranty lasts or exclusions or limitations of incidental or consequential damage, so the limitations and exclusions in the warranty may not apply to you. This warranty gives you specific legal rights, and you may also have other rights, which vary from state to state.