

CART FOR CENTURION 1500+

Operation & Maintenance Manual

www.amerewater.com • 800-535-5585

AmeriWater • 3345 Stop 8 Rd. • Dayton, OH 45414

98-0161 Rev A

Contents

1. GENERAL INFORMATION	1
1.1. Features	1
2. SAFETY	2
2.1. Warnings	2
2.2. Feed Water Requirements	2
3. OPERATION	3
3.1. Installation	3
3.2. Adjusting Inlet Pressure	5
4. MAINTAINENCE	7
4.1. Surface Cleaning	7
4.2. Filter Replacement Interval	7
4.3. Recommended Monitoring	7
4.4. How to Replace Cartridge Pre-filters	8
4.5. Initial Rinse and Testing	8
4.6. Operational Testing	9
5. SPARES	10
5.1. Replacement Filters	10
5.2. General Spares	10

1. GENERAL INFORMATION

The Cart for Centurion 1500+ is a compact solution to moving the pretreatment and Centurion 1500+ to treat individual patients in acute settings. The cart is designed to carry the Centurion 1500+, cartridge pre-filter, (2) carbon block filters, and all hoses and power cords needed to operate the RO system. The pretreatment system is designed to remove up to 1 micron sediment, chlorine and/or chloramines from the incoming feed water supply. The cart system allows the Centurion to provide RO water for bedside use and is intended for use in hospitals, clinics, and dialysis centers. The Cart for the Centurion 1500+ is constructed of aluminum to keep the weight low. The cart is coated in an off-white powder coating to increase corrosion resistance.

1.1. Features

- The ability to transport the Centurion 1500+ portable heat disinfection reverse osmosis (RO) system from patient to patient in acute settings.
- (1)- 1 micron spiral wound 2.5"x10" sediment pre-filter
- (2)- 2.5"x20" carbon block filters for chlorine and/or chloramine removal
- Storage for all tubing and cables associated with the operation of the centurion 1500+

CAUTION: No person should attempt to operate or service the AmeriWater RO+ without prior authorization, instruction, and training from AmeriWater and/or your medical facility director.

2. SAFETY

2.1. Warnings

This Operation manual should be read and understood prior to system operation. This manual can be used for reference or future training.



Electrical:

Care should be used when unplugging the Centurion 1500+. Refer to the manual for the Centurion 1500+ for proper care when handling the power cord for the system.



Labeling:

Do not remove any labeling found on the Cart for the Centurion 1500+. All labels are necessary for system safety and operation

2.2. Feed Water Requirements

NOTE: Consult the Operation manual for the Centurion 1500+ for the feed water requirements for proper operation.

3. OPERATION

3.1. Installation

The Centurion Cart is designed to orient the Centurion 1500+ so that all water connections are contained within the confines of the cart. The following steps show the proper way to place the Centurion onto the cart. The cart is equipped with 2 straps that allow the water and electrical connections to be stored when not in use.

1. Rotate the Centurion so that the ultrafilter is accessible without removing the system from the cart

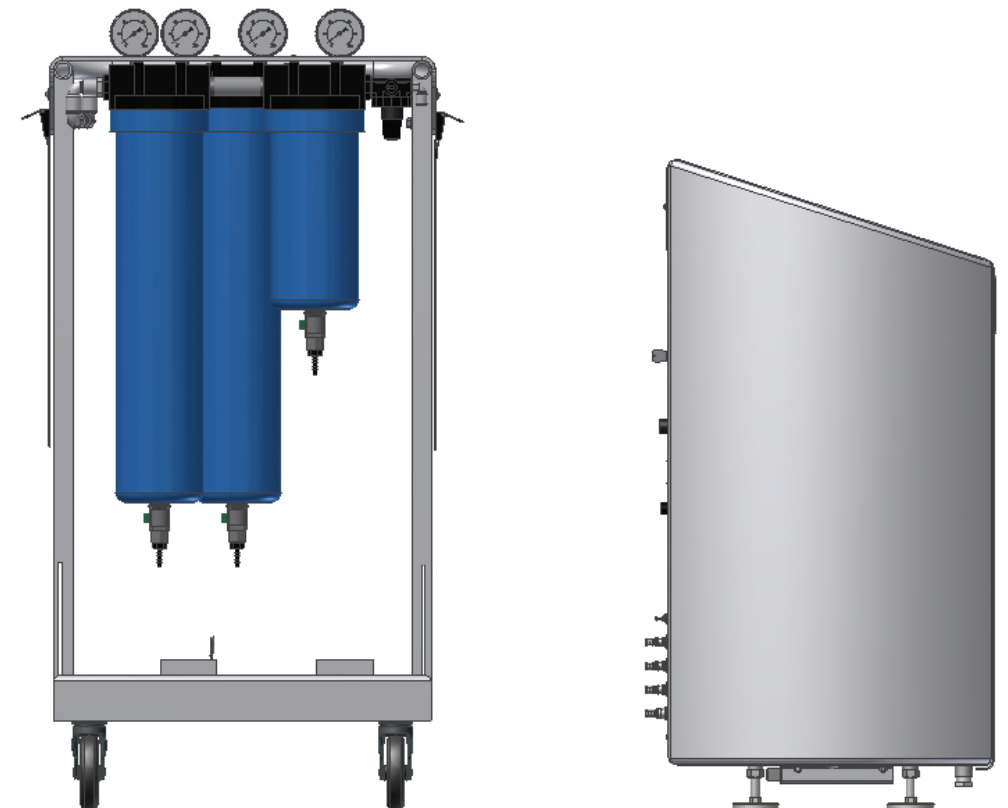

2. Carefully lift the unit (may require 2 people) onto the cart. Slide the feet into the feet mounting brackets on the Centurion.



3. Place the locking pin in the hole on the cart to secure the left front foot of the Centurion to the cart.

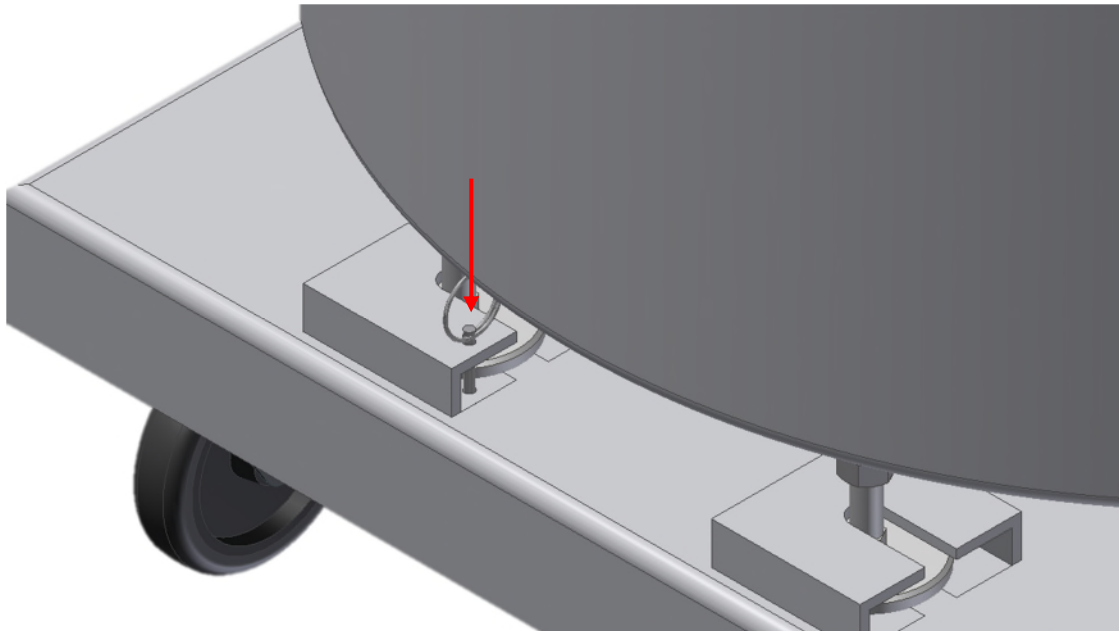

4. The Centurion should be mounted to the cart as shown in the following figures.



3.2. Adjusting Inlet Pressure

The cart for the Centurion is equipped with a **0-60 psi** pressure regulator on the inlet of the pretreatment filters. The inlet pressure should be set to **50 psi** by default, but can be adjusted using the following steps.

1. Pull down on the knob at the bottom of the pressure regulator.

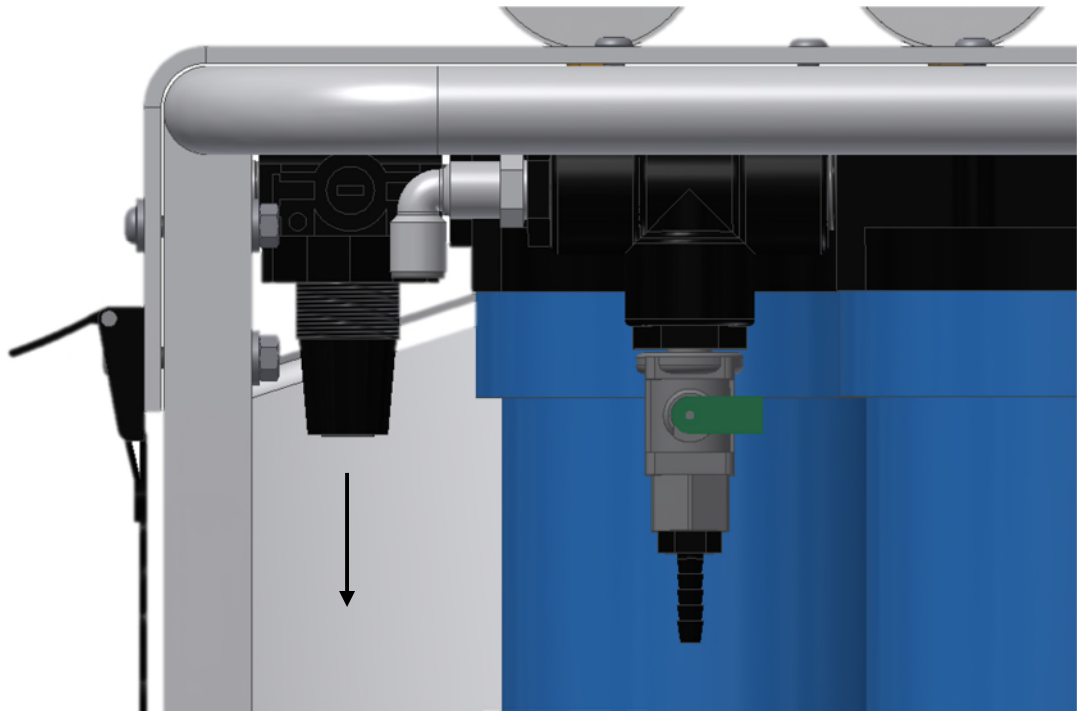

2. Turn the knob Clockwise (↻) to decrease the pressure or Counter Clockwise (↺) to increase the pressure.
3. Watch the “Pre-filter Inlet PSI” gauge and set the pressure to the desired level.
4. When desired pressure level is reached, push the knob up and be sure it is locked to prevent unwanted variation of pressure.

4. MAINTAINENCE

4.1. Surface Cleaning

The cart for the Centurion 1500+ is constructed of powder coated aluminum. The cart may be wiped down before moving into areas where surface contamination is not acceptable. Wipe down may be conducted using EPA approved low level cleaners. A 70% maximum Isopropyl alcohol concentration is the recommended disinfectant used to wipe down the surfaces of the cart. Always use a soft, non-abrasive cloth to wipe down the surface of the cart. Pre-wetted wipes are recommended if available.

4.2. Filter Replacement Interval

The pretreatment filters used for the Centurion cart are considered consumables. These items are required to be replaced periodically to maintain quality performance from the pretreatment. The following table tells the recommended replacement interval for the pretreatment filters.

Filter Type*	Replacement Interval**	QTY
Sediment Filter	Monthly	1
Carbon Block Filter	Every 3 months	2

* Filter part numbers can be found in **Section 4**

** Filters may require more frequent replacement depending on site conditions. Pressure drop >10 psi may indicate the filter needs replaced.

4.3. Recommended Monitoring

Item to monitor	What to monitor	Typical range of values	Typical interval	Comments
Pre-filter Gauges	Pressure	At least 20 PSI	Daily	NA
Pre-filter Gauges	Pressure drop across filter(s)	Within 10 PSI of the value originally recorded on the STARTUP LOG	Daily	NA
Carbon filtration	Total chlorine at Chloramines Sample Port	< 0.1 mg/l of total chlorine	Daily	Prior to each patient shift.

4.4. How to Replace Cartridge Pre-filters

1. Power off the Centurion using the ON/OFF switch on the rear of the unit. Unplug system from the mains power supply.
2. Relieve any pressure from the pretreatment filter assembly using the chloramine sample port.
3. Use the filter wrench to unscrew the filter housing.

CAUTION: Even after relieving the pressure from the Chloramine Sample Port, the filter bowls will be full of water. Carefully remove housings.

4. Remove and discard the used filter.
5. Partially unwrap the plastic from the new filter. Holding the end covered with plastic, place the new filter in the housing. Discard the remaining plastic after installation.
6. Apply O-ring lube sealant to the O-rings for the cartridge filter housings. Screw the filter housing back on making **sure** the O-ring is in the groove, and not pinched. Hand-tighten, only.

4.5. Initial Rinse and Testing

1. With the feed water supply connected to the pre-filter inlet and the pre-filter outlet routed to a drain, allow the filter sumps to fill with water.
2. Allow water to flow through the carbon block filters and sediment filter for at least 2 minutes to remove any contaminants.
3. Inspect for leaks at all threaded connections.
4. When the flushing is complete, turn off the feed water supply. Remove the pre-filter outlet from the drain and connect to the Centurion "INLET".
5. Slowly open the feed water supply and allow any air to bleed off by slightly opening the sample ports. Once the air is bleed out, close the sample ports and check for any leaks.
6. Test the Primary and Secondary Chloramine Sample Port for the absence of chlorine. If the total chlorine level is $\geq .1$ mg/L of chlorine the carbon block filters may need replaced.

4.6. Operational Testing

1. Open the feed water supply.
2. Record the water pressure from the pressure gauges on the cart.
3. Turn the RO on and allow the system to run for 15 minutes. Operating pressure should be at least 20 psi. the pressure differential across the pre-filter assembly should not exceed 10 psi.
4. Test the chlorine level at the Primary and Secondary Chloramine Sample Port. Always confirm the absence of chlorine before beginning treatment. If the total chlorine test is $\geq .1$ mg/L of chlorine the carbon block filters may need replaced.
5. Refer to the test strips for proper sampling procedure.

5. SPARES

5.1. Replacement Filters

Part Number	Description	QTY
20-1011	FILTER CARTRIDGE POLY SPUN, 1 MICRON, 2.5" X 10", DOE	1
20-5012	FILTER, CARBON BLOCK, 2.5" X 20" (FOR CHLORAMINES)	2

5.2. General Spares

Part Number	Description
0112-0028	HOSE ASSY, MROS, Centurion cart INLET, 8' .38 hose
041002	VAL,BALL,.25,MPTXFPT,PVC80 NIBCO-CHEMTAINER
041531829	NIPPLE,.75XCL,PVC80
046520420	BUSH,.75X.25,THRD,PP
046520421	TEE,.75,THRD,PP
046531845	BUSH,.75X.5,THRD,PP
08760164	TUBING,.50OD,NYLON,250PSI,BLACK
10521027	ADPT,CON,.25STEMX.25HB
10-L107	LEGRIS SWIVEL EL,MALE, 0.5T X 0.5MPT
10-L378	LEGRIS PLUG-IN EL, 0.5T X 0.5STEM
14760335	ADPT,.25MPTx.25HB,PP
21-0028	FLTR,HOUS,2.5X20,.75,I/O,DOE
21540114	FLTR HOUS,2.5X10,.75F/T
43530711	GAUGE,0-100,.25,BM,2.5,LF,SS/BR
44-0002	REGULATOR VALVE,PLASTIC,.38NPT
046531849	BUSH,.75X.38,THRD,PP
10-L054	LEGRIS FIXED EL,MALE, 0.38T X 0.38MPT
10-L105	LEGRIS SWIVEL EL,MALE, 0.38T X 0.38MPT
041531158	NIPPLE,.75x4,PVC80
041730198	NIPPLE,.38XCL,PVC80