

Central Sterile Silex

00HC-2002 and 00HC-2003



TABLE OF CONTENTS

TABLE OF CONTENTS.....	1
1 USER INFORMATION	2
1.1 Introduction.....	2
1.2 Electrical Leakage Standards.....	2
2 TECHNICAL INFORMATION	3
2.1 System Specifications	3
2.1.1 00HC-2002.....	3
2.1.2 00HC-2003.....	4
2.2 Theory of Operation	4
2.3 System Components.....	5
2.3.1 00HC-2002.....	5
2.3.2 00HC-2003.....	6
3 SYSTEM INSTALLATION.....	7
3.1 Pre-Installation Requirements	7
3.2 General Installation	7
3.3 Silex Installation.....	7
4 SYSTEM START-UP PROCEDURES.....	8
5 MONITORING.....	10
5.1 System Monitoring.....	10
5.2 AAMI Monitoring	11
6 DISINFECTION.....	12
6.1 Disinfection Procedure	12
6.1.1 Disinfecting the Silex.....	12
7 MAINTENANCE.....	13
7.1 Resin Pack Exchange	13
7.2 Filter Cartridge Replacement	14
7.3 Resin Pack Regeneration.....	15
8 TROUBLESHOOTING AND REPAIR.....	16
8.1 Troubleshooting Chart	16
8.2 Cleaning the Pump	16
8.3 Changing the Rotors on the Pump.....	17
9 SPARE PARTS LISTING	18
CALIFORNIA PROPOSITION 65	19

1 USER INFORMATION

1.1 Introduction

This system is designed to pretreat and purify water for use in healthcare applications. The system is shipped with required water treatment components. This Operation Manual was written specifically for the Silex model. Your system was thoroughly tested and in excellent condition when it was shipped to you. However, because damage during shipment is possible, please unpack and carefully inspect the system as soon as you receive it. Please notify AmeriWater if any problems are encountered.

Please read the Operation Manual before using the system. Contact AmeriWater Customer Service with any questions at 1-800-535-5585 Monday through Friday 8:00 a.m. to 5:00 p.m. Eastern Time. For after-hours emergencies call 1-800-535-5585 and follow the instructions on the recorded message. Our on-call technician will return your call as soon as possible. This entire Operation Manual should be read before operating or servicing the system. This Operation Manual should then be kept near the system and used as a reference and troubleshooting guide.

1.2 Electrical Leakage Standards

The AmeriWater Silex water treatment systems comply with the IEC 61010-1 Standards for Product Safety and Construction.

The columns of the Silex is PVC for additional operator safety.

The Silex is compliant with the IEC 61010-1 Safe Current Limits. All major components of the Silex (controller, pump, solenoid valve, antiscalant pump, etc.) are UL listed.

2 TECHNICAL INFORMATION

2.1 System Specifications

2.1.1 00HC-2002

00HC-2002				
Maximum Incoming Water Temperature		100° F (38° C)		
Inlet Pressure Minimum		Pressure regulator prevents inlet pressures above 50 PSI 10 PSI		
Flow Rate		3 GPM		
Power Ratings	Voltage	Frequency	Phase Ø	Amp Draw
	115 VAC	60HZ	1Ø	1.4 A
Silex Connection		Inlet	Outlet	Outlet Hose
		¾" FGHT	¾" MGHT	3' ¾" FGHT to ½" FPT
Electrical Requirements		Power: 115V/60Hz/15A dedicated Dual Outlet GFI (G round F ault I nterrupter)		
Capacity		½ cu ft per housing		
System Dimensions		24" L x 16½" D x 42" H		
Shipping Weight		150 lbs.		

2.1.2 00HC-2003

00HC-2003	
Maximum Incoming Water Temperature	110° F (43° C)
Inlet Pressure Maximum Minimum	50 PSI 10 PSI
Flow Rate	4 GPM
Silex Connection	Inlet
	Outlet
	¾" FGHT
	20' hose ¾" FGHT
Electrical Requirements	Power: 115V/60Hz/15A dedicated Dual Outlet GFI (G round F ault I nterrupter)
Capacity	½ cu ft per housing
System Dimensions	21 ½" L x 13" D x 41" H
Shipping Weight	65 lbs.

2.2 Theory of Operation

This system is designed to polish the RO product water in order to provide purified water used in laboratory applications. The facility's tap water first passes through the RO, then enters the first deionizer column (worker) where the deionizer resin removes chemical contaminants from the water through an ion exchange process. The water then passes into the "polisher" column. As water leaves the polisher, the purified water passes through a 1M ohm resistivity monitor with alarm and on to the storage tank.

2.3 System Components

2.3.1 00HC-2002

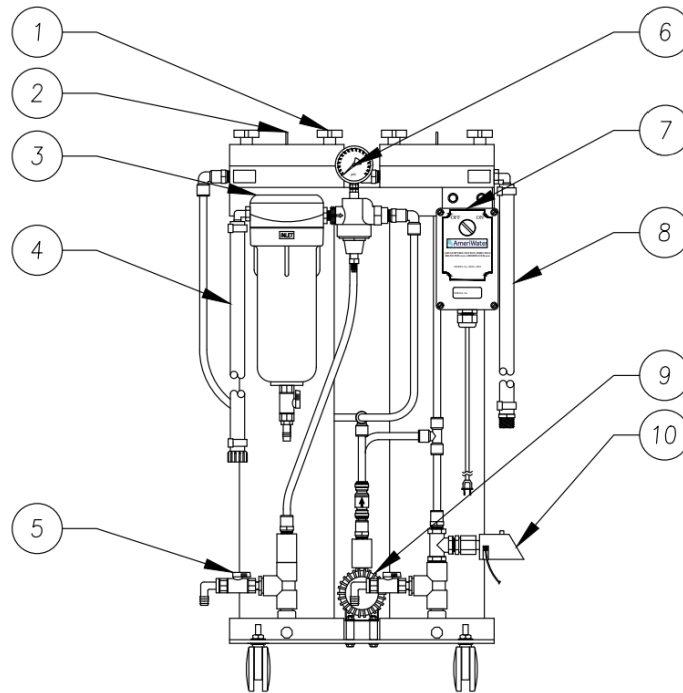

Figure 1: Silex Front View

IDENTIFICATION OF COMPONENTS (Figure 1)

1. **COVER PLATE KNOBS:** Knobs to secure the cover plate to the upper plate.
2. **AIR VENT SCREWS:** Vents provided to break the vacuum seal to facilitate resin changes.
3. **CARBON CARTRIDGE FILTERS:** 10-micron carbon cartridge for removal of chlorine.
4. **WATER INLET HOSE:** Hose feeding incoming water into the Silex system.
5. **DRAIN VALVES:** Valve transmitting wastewater to the drain.
6. **PRE-FILTER INLET GAUGE:** Gauge that measures the pressure in pounds per square inch (PSI) of the incoming water as it enters the carbon block pre-filter.
7. **CONTROL BOX:** Control mechanism for the Silex system.
8. **WATER OUTLET HOSE:** Hose transmitting the deionized product water.
9. **LAING ECOCIRC PUMP:** Providing the driving pressure for the Silex system.
10. **1,000,000 OHMS QUALITY LIGHT:** Light with alarm that will indicate when the water is outside of the limit.

2.3.2 00HC-2003

Figure 2 00HC-2003 Front View

IDENTIFICATION OF COMPONENTS (Figure 2)

- 1. COVER PLATE KNOBS:** Knobs to secure the cover plate to the upper plate.
- 2. AIR VENT SCREWS:** Vents provided to break the vacuum seal to facilitate resin changes.
- 3. WATER INLET HOSE:** Hose feeding incoming water into the Silex system.
- 4. DRAIN VALVES:** Valve transmitting wastewater to the drain.
- 5. WATER OUTLET HOSE:** Hose transmitting the deionized product water.
- 6. 1,000,000 OHMS QUALITY LIGHT:** Light with alarm that will indicate when the water is outside of the limit.

3 SYSTEM INSTALLATION

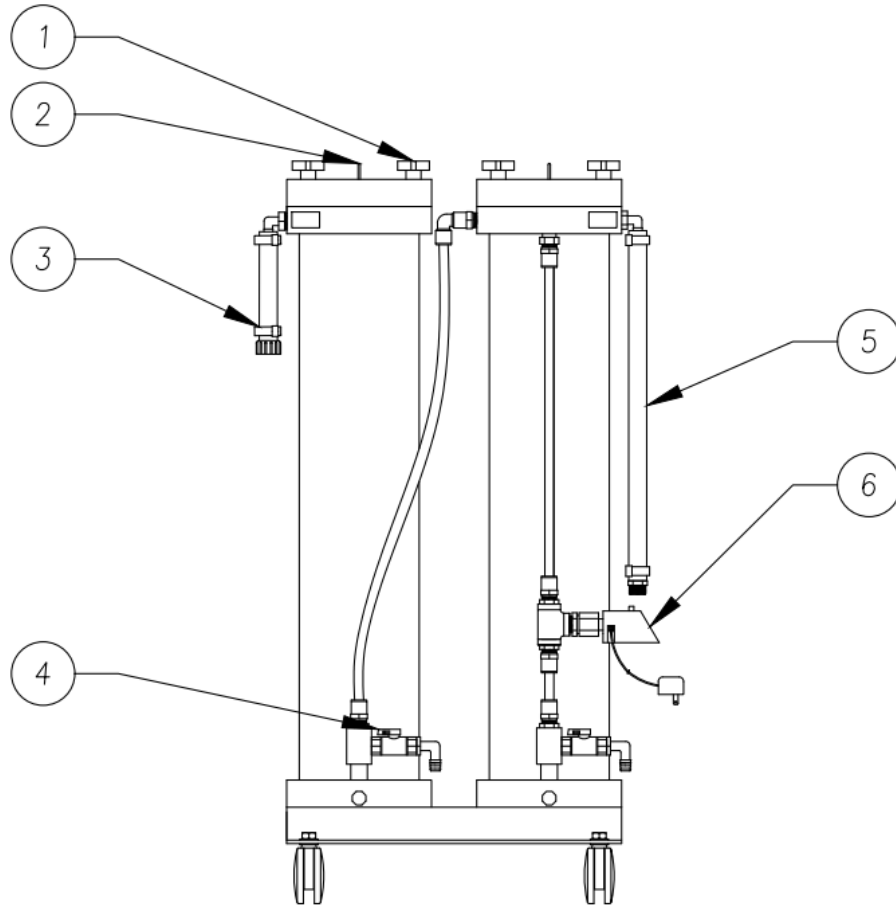
3.1 Pre-Installation Requirements

1. Electrical: see Section 2.1.
2. RO installation and start-up steps completed.
3. Floor drain within 4 feet of the RO/DI system capable of handling up to 10 GPM flow.
4. Supply piping to the washer/disinfecter/sterilizer system(s) within 3 feet of the RO/DI distribution pump with a shut off valve.
5. Access space of 1 foot on each side and behind the water treatment equipment with a 3 foot aisle in front of the equipment or required to meet local codes.

3.2 General Installation

1. Two (2) hose clamps are to be used per hose connection.
2. A visual inspection is to be performed upon finishing installation and start-up of each system to ensure each component will function as intended. This includes, but is not limited to: lids and respective O-rings are not damaged or loose, damaged or loose hoses, leakage, secured power outlets, etc.

3.3 Silex Installation

For 00HC-2002:

1. Locate the DI Polisher on a firm, level foundation to the right of the RO, just before the storage tank. It is recommended, but not required, to locate the system near a standard floor drain or sump and a 115 Volt receptacle. This receptacle is where the power supply cord will be plugged in.

CAUTION: Vent all plumbed drain lines in accordance with local plumbing codes and / or local regulations. If a drain is not feasible, mount the system on a raised platform so that it can be drained into a container.

2. Route the product water hose from the RO behind the RO to connect to the DI Polisher hose inlet after disinfection.
3. Connect the water inlet to the garden hose fitting on the inlet hose.
4. Install the water outlet hose to the point of use. This system has been shipped with a 3/4" MPT fitting installed on the outlet hose. A 3/4" FPT coupling has also been provided.
5. Install the carbon cartridge in the bowl of the filter housing.
6. The ON/OFF switch on the control box should be set at OFF. Plug the power cord into a 115-volt outlet.

For 00HC-2003:

7. Locate the DI Polisher on a firm, level foundation to the right of the RO, just before the storage tank. It is recommended, but not required, to locate the system near a standard floor drain or

sump and a 115 Volt receptacle. This receptacle is where the power supply cord will be plugged in.

CAUTION: Vent all plumbed drain lines in accordance with local plumbing codes and / or local regulations. If a drain is not feasible, mount the system on a raised platform so that it can be drained into a container.

8. Route the product water hose from the RO behind the RO to connect to the DI Polisher hose inlet after disinfection.
9. Connect the water inlet to the garden hose fitting on the inlet hose.
10. Install the water outlet hose to the point of use. This system has been shipped with a 3/4" MPT fitting installed on the outlet hose. A 3/4" FPT coupling has also been provided.
11. Plug the power cord into a 115-volt outlet.

4 SYSTEM START-UP PROCEDURES

NOTE: This entire Operation Manual should be read before operating or servicing the Silex system. The Operation Manual should then be kept near the system and used as a reference and troubleshooting guide.

1. For the 00HC-2002 models, the ON/OFF switch on the control box should be set at OFF. This switch will activate the pump and monitor light. There must be water through the Silex system before turning the switch to the ON position. A green light located on the switch also indicates that the unit is on. Attention: Running the pump dry may cause premature failure.
2. The Silex Deionizer is designed to operate at pressures up to 50 PSI (**P**ounds per **S**quare **I**nch). The maximum flow for each deionizer is listed in Section 2.1.
3. Install the resin pack(s):
 - a. Remove the cover plates by unscrewing the four black knobs on each plate. To break the seal between the cover plates and the upper plates, use a slotted screw driver in the pry notch located in the top of each upper plate. Open the drain valve at the bottom of each column.



- b. Remove the resin pack from the shipping box and open the tied end of the plastic sleeve. DO NOT remove the resin pack from the plastic sleeve at this time.
- c. Stretch the resin pack over your arm to elongate the pack, and feed it into the Silex column allowing the pack to slide out of the plastic sleeve.



- d. Replace the cover plate and tighten the black knobs. Be sure to tighten the knobs evenly by screwing in the knobs in opposite corners simultaneously. Repeat for the other two corners.

CAUTION: Failure to tighten the knobs completely may cause the cover plate to separate from the system when pressurized.

- e. Close the drain valve at the bottom of the column.
 - f. Repeat steps a. through e. for each of the columns.
4. Open the air vents located on the top of the cover plates and turn on the water supply. Tighten the air vents closed when water begins to escape through the vents.
 5. Allow several gallons of water to run through the Silex system. Continue running water through the system until the water quality light changes from red to green. The green light indicates that the Silex is producing deionized water.



5 MONITORING

5.1 System Monitoring

Fill out the monitoring log prior to each use. Having this information available will help to quickly diagnose issues related to performance. Failure to carry out the daily monitoring and maintenance at the indicated intervals will result in reduced performance of the Silex system and may void the warranty. Below is a sample log.

PRE-FILTRATION	Parameters	Results	Date	Initials
Blend Valve Temperature	77°F ± 5°F			
Chlorine Test	≤ 0.1PPM			
RO OPERATION	Parameters	Results	Date	Initials
Prefilter Inlet Pressure	> 25PSI			
Prefilter Outlet Pressure	> 25PSI			
Prefilter Delta Pressure (Subtract Inlet by Outlet)	≤ 10PSI			
Pump Pressure	100 – 230 PSI			
Reject Pressure (PSI)	Record			
Flowrate (GPM)	Record			
Reject Flowrate (GPM)	Record			
Recirculation Flowrate (GPM)	Record			
Conductivity	< Alarm Set-point			
Percent Rejection	> 95%			
Amount of Hours in Operation	Record			
POST RO	Parameters	Results	Date	Initials
Distribution Pump Outlet	Record			
Storage Tank Loop Return Pressure	Record			
Storage Tank Loop Return Flowrate	Record			
DI Packs / Tank Providing Adequate Resistance	Green Light			
UV Intensity	> 50%			
Endotoxin Filter Delta Pressure	< 10PSI			
Verify System Normal Display on Main Alarm Panel	Record			
Verify Good Quality Light on Remote Alarm Panel	Green Light			
Verify Loop Resistivity Display on Main Alarm Panel	Record			
EXCHANGE	Date	Initials		
Carbon Block Filter Cartridges				
Clean or Replace the Membrane				
Add PT401 (Anti-scalant)				
DI Polisher Resin Change				
Endotoxin Replaced				
Storage Tank Vent Filter				

5.2 AAMI Monitoring

Reference the Association for the Advancement of Medical Instrumentation (AAMI), for detailed guidelines on addressing water treatment equipment, water quality specifications, and procedures for monitoring water quality.

6 DISINFECTION

The following section will outline the disinfection steps for the Silex. Refer to Section 5.2 for AAMI standards for disinfection.

6.1 Disinfection Procedure

Be sure to refer to your facilities Start-Up Log. This will help you verify that all steps are performed and recorded to disinfect the system properly.

6.1.1 Disinfecting the Silex

1. For 00HC-2002 models, turn the ON/OFF switch on the control box to OFF.
2. Turn off the water supply to the Silex system.
3. Remove resin packs from the system. For 00HC-2002 models, remove the filter as well. Reference the instructions for resin pack and filter exchange in Section 7.
4. Pour one tablespoon of household chlorine bleach (5% solution) into the filter sump.
5. For each Silex column, pour in one tablespoon of household chlorine bleach (5% solution).
6. Close all drain valves, sample ports, and filter drains and open the air vents located in the center of the top plates.
7. Turn on the water supply to the Silex system and allow the system to fill with water until the presence of chlorine can be detected at the outlet of the system.
8. Turn off the water supply to the Silex system and allow the system to soak for 15 minutes.
9. After the 15-minute soak time, turn on the water supply to the system. Allow the system to flush until chlorine is no longer detected.
10. Drain the water out of the system by placing a container under the drain valves and opening the valves. Place the container under the filter drains and open the valves to drain the water out of the filter sump. Close all valves when water is no longer flowing out of them.
11. Install new resin packs in the Silex columns and for 00HC-2002 models new filter cartridge in the filter sump as well. Reference the resin pack and filter exchange instructions in section 7.1 and 7.2.

7 MAINTENANCE

Apart from regular resin pack exchange and periodic disinfection, the Silex system requires no maintenance. In the event that the system is damaged, all parts can be ordered from AmeriWater.

7.1 Resin Pack Exchange

The resin has a shelf life of approximately one year. The resin pack consists of resin contained in a polypropylene bag that never has to be opened. Resin packs are shipped in plastic sleeves to prevent the exchanges from drying out. Follow aseptic procedures while performing exchange.

1. For 00HC-2002 models, turn the ON/OFF switch on the control box to OFF.
2. Turn off the water supply to the Silex system.
3. Open the air vents located in the center of the cover plates.
4. Place a container under the Drain Valves located on the bottom plates of the system. Open the valves and allow the water to drain into the container. The container may be emptied at a drain.
5. Remove the cover plates by unscrewing the black knobs located at each corner of the cover plates.
6. Pull the exhausted resin pack part of the way out of the column and lay it over the top of the system.

NOTE If the Drain Valve located on the bottom plate is not open, a vacuum will be created making it difficult to remove the resin pack.

7. Slowly pull the exhausted pack over the side of the column while sliding it out of the column and into the plastic sleeve that it was shipped in.
8. Remove the new resin pack from the shipping box and open the tied end of the plastic sleeve. Stretch the resin pack over your arm to elongate the pack. Feed the pack into the column allowing it to slide out of the plastic sleeve. Save the plastic sleeve for the return shipment of the resin pack at the next exchange.
9. Carefully wipe the O-rings and the grooves on the top plate and cover plate to remove any debris from the surfaces that must seal together.
10. Replace the cover plates and tighten the knobs. To ensure proper tightening and a good seal, tighten the knobs in opposite corners simultaneously. Repeat for the other two corners.
11. Turn on the water supply to the Silex system and remove trapped air by loosening the air vents located in the center of the cover plates. Tighten the air vents when water begins to escape through the vent. This ensures that all of the air has been removed from the system and maximizes the life and efficiency of the resin packs.
12. Allow water to run through the system for 1 to 2 minutes prior to placing the Silex system in service.
13. For 00HC-2002 models, turn the switch on the control box to ON.

7.2 Filter Cartridge Replacement

The carbon cartridge should be replaced each time the resin pack(s) are exchanged. This applies only to the 00HC-2002 models.

1. Turn the ON/OFF switch on the control box to OFF. Turn off the water supply to the system.
2. Place a container under the filter housing sump and open the filter drain port on the bottom of the sump to drain the water out of the filter housing. Close the filter drain when water ceases to flow out of them.
3. Use the filter wrench supplied in the installation kit to turn the filter housing counterclockwise.
4. Remove and discard the old filter cartridge.
5. Partially unwrap the plastic from the new filter cartridge. Holding the end covered in plastic, place the new filter cartridge in the housing. Discard the plastic wrapper after installation.
6. Screw the filter housing back on making sure the O-ring is in the groove and is not pinched.
7. Turn on the water supply to the system. Turn the ON/OFF switch on the control box to ON.

7.3 Resin Pack Regeneration

Regeneration certificates are used to simplify the exchange of your exhausted DI Polisher system packs. The certificate has been purchased and will be used as payment for the resin pack regeneration service. Simply follow these steps:

1. Fill out a regeneration certificate by printing your name, phone number, company and address.
2. When you send each pack to AmeriWater, enclose the regeneration certificate in the box. AmeriWater will ship you a freshly regenerated resin pack.
3. To order more certificates, contact the company that originally sold you the deionizer. Be sure to keep regeneration certificates on hand to ensure uninterrupted service.
4. It is recommended to send the exhausted resin to AmeriWater immediately after exchange. This will allow time for shipment and will maintain your uninterrupted supply of deionized water.



Pre-Paid Resin Regeneration Certificate

This certificate has been purchased and will be used as payment for the resin pack regeneration service.

When you send each pack to AmeriWater, enclose this regeneration certificate in the box. AmeriWater will ship you a freshly regenerated resin pack. To order more certificates, contact the company that originally sold you the deionizer.

Fill out for return shipment to:



Ship exhausted pack and certificate to:
AmeriWater
 3345 Stop 8 Rd
 Dayton, OH 45414

Name _____

Phone _____

Company _____

Address _____

Address _____

City _____

State/Zip _____

DI-2101C Standard Resin Pack (.5 cubic feet)

Fill out and enclose in box for return shipment

8 TROUBLESHOOTING AND REPAIR

8.1 Troubleshooting Chart

WARNING: Only those persons who have read the complete operations manual or who have received authorization from the medical facility director should attempt to troubleshoot and/or repair the RO system.

To assist you in quickly restoring your system into service, AmeriWater will send your replacement part out immediately and check your bad part when it comes in to verify if it is covered under your equipment warranty.

PROBLEM	POSSIBLE CAUSE	CORRECTIVE ACTION
Pump does not run	<ol style="list-style-type: none"> 1. Thermal overload protection switched off the pump 2. Pump is blocked 3. Pump fluid is too hot 	<ol style="list-style-type: none"> 1. Wait for the pump to cool and it will start again. 2. Turn the pump OFF and close the shut off valves. Open the screw ring carefully and clean the pump of impurities. 3. Make sure the fluid through the pump is between the allowable values. See section 2.1.
Loud flow noises	<ol style="list-style-type: none"> 1. System was not purged correctly 2. There may be dirt in the pump housing 	<ol style="list-style-type: none"> 1. Flush the system making sure it is filled and the air has been forced out. Turn the system OFF and loosen the screw ring a little bit so air can leak out from the pump. Carefully open the lead-in and fasten the screw ring. Turn the pump back ON. If noises don't stop after a few minutes, repurge the system. 2. Turn the pump OFF and close the shut off valves. Open the screw ring carefully and clean the pump of impurities.

8.2 Cleaning the Pump

For 00HC-2002 models only.

The pump must be without power. Turn the ON/OFF switch on the control box to OFF. Close the shut-off valves. Open the screw ring carefully. Attention: water will run out of the pump. Avoid electric parts from getting wet or water running over the motor. Take away the stator. Take out the rotor carefully by grabbing it at the blade wheel. Check the pump housing, the rotor and the stator for impurities and remove them. Clean the pump.

8.3 Changing the Rotors on the Pump

For 00HC-2002 models only.

Put the rotor back in the stator and check whether it can be turned easily. If not, the bearing might be worn (swirl marks on the bottom side of the rotor). Put in the new rotor. Change the pump against a new one. If the rotor can be turned easily, close the pump again. Remove the gasket. Clean the gasket and the nut and the area on the stator where the gasket lays. Put the gasket back inside the pump housing. Assemble the stator with the screw ring. The screw ring must not be installed using tools. Normally it is enough to assemble the screw ring manually. If the pump does not work, replace the motor.

9 SPARE PARTS LISTING

Description	Part Number
Regeneration Certificate, Standard DI	DI-45101C
Pack DI Standard Regeneration	DI-45101S
Filter Cartridge Carbon Block, 10 Micron, 2.5"x10" DOE	20-5101
Laing Ecocirc Pump	80-0137
Drain Tee Assembly	0119-0067
Column, Silex Assembly	0119-0010
Washer	14570111
Silex O-Ring	19300001-00
Air Vent	19530901
Knob Assembly	19560310
Filter Housing O-Ring	21530234
Gauge	43530701
Regulator	44-0065
Hydro-Check, 1M Ω Light with Alarm	75679117
Caster, Twin Wheel with Brake	94560410
Caster, Twin Wheel no Brake	94560411
Power Supply	62-0012
Switch	65-0011
Switch Contact	65-0012
XFMR,50/60HZ,1PH,110VAC-12VDC I/O Transformer	75679118
Ball Valve	041002
JGES Check Valve	55-0013

CALIFORNIA PROPOSITION 65

 WARNING

This product can expose you to chemicals such as vinyl chloride (used in the production of PVC) or Nickel (used in the production of stainless steel), that are known to the State of California to cause cancer. For more information go to www.P65Warnings.ca.gov.

Dear Valued Customer,

California Proposition 65 (Prop 65) is the Safe Water and Toxic Enforcement Act of 1986. The State of California began enforcing amendments to California Prop 65 at the end of August 2018. Prop 65 requires manufacturers to provide a clear and reasonable warning to residents of California about chemicals used in products that they purchase that are included on the Prop 65 Chemical List. The chemicals included on the list are chemicals that are known to the State of California to cause cancer, birth defects, or other reproductive harm. One such chemical is Vinyl Chloride, a compound used to produce Polyvinyl Chloride (PVC). The AmeriWater system you have purchased may contain PVC or stainless steel parts.

While warnings are only required in the State of California, AmeriWater has initiated the use of Prop 65 labeling for all products to ensure compliance with California regulations. Please note that the above warning does not necessarily mean that the product that you have purchased is unsafe. Products that have been cleared for market by FDA have been determined to be safe and effective by the United States Food and Drug Administration. The warning is simply a requirement by the State of California. If you wish to obtain additional information, please visit: p65warnings.ca.gov. You may also contact your AmeriWater representative if you have any questions.

Thank you for your understanding and we look forward to continuing to serve you.